

# KIT FRAME LIFTER-PRESS AND PUMP FOR GREASE AND HIGH VISCOSITY FLUIDS



**012-1340-P60**

## Art. 012-1320-P60

Kit pump frame lifter and press for grease for drums 180-220 kg with pump R=20:1 Delivery 12 kg/min

Composed by:

Art.012-1200-050 Pump frame lifter and press 2 columns + follower plate

Art.011-0920-P60 Industrial air operated pump **R=20:1**

Art.902-0323-015 Rubber hose R6 3/8" length 1,5 m F-F 3/8"

Art.902-0424-015 Rubber hose R6 1/2" length 1,5 m F-F 1/2"

## Art. 012-1340-P60

Kit pump frame lifter and press for grease for drums 180-220 kg with pump R=40:1 Delivery 10 kg/min

Composed by:

Art.012-1200-050 Pump frame lifter and press 2 columns + follower plate

Art.011-1240-P60 Industrial air operated pump **R=40:1**

Art.902-0323-015 Rubber hose R6 3/8" 1,5 m length F-F 3/8"

Art.902-0424-015 Rubber hose R6 1/2" 1,5 m length F-F 1/2"

## Art. 012-1350-P50

Kit pump frame lifter and press for grease for drums 180-220 kg with pump R=50:1 Delivery 6,8 kg/min

Composed by:

Art.012-1200-045 Pump frame lifter and press 2 columns + follower plate

Art.011-0950-P50 Industrial air operated pump **R=50:1**

Art.902-0323-015 Rubber hose R6 3/8" 1,5 m length F-F 3/8"

Art.902-0424-015 Rubber hose R6 1/2" 1,5 m length F-F 1/2"

## Art. 012-1370-P50

Kit pump frame lifter and press for grease for drums 180-220 kg with pump R=70:1 Delivery 6,0 kg/min

Composed by:

Art.012-1200-045 Pump frame lifter and press 2 columns + follower plate

Art.011-1270-P50 Industrial air operated pump **R=70:1**

Art.902-0323-015 Rubber hose R6 3/8" 1,5 m length F-F 3/8"

Art.902-0424-015 Rubber hose R6 1/2" 1,5 m length F-F 1/2"



<b>012-1320-P60</b>	246,600	1,920	1
<b>012-1340-P60</b>	247,900	1,920	1
<b>012-1350-P50</b>	247,400	1,920	1
<b>012-1370-P50</b>	248,600	1,920	1

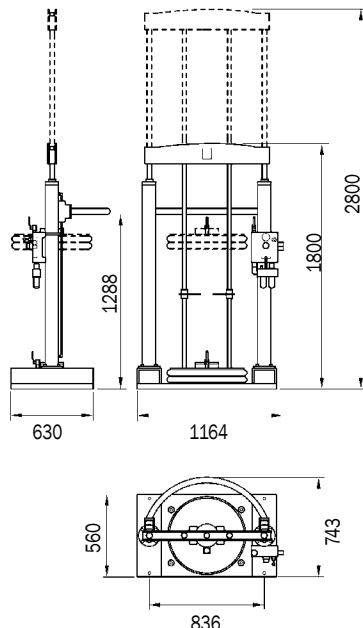
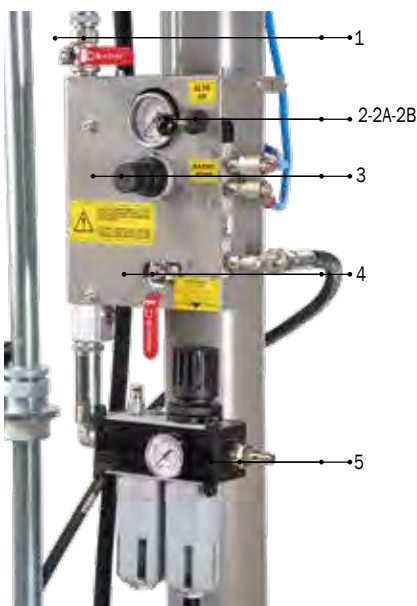

- |    |   |   |  |
|----|---|---|--|
| 1  | Cock for pump air supply                        | 3 | Pressure regulator with manometer for air supply of the lifter |
| 2  | Off position                                    | 4 | Cock for air supply to lift the follower plate                 |
| 2A | Up position to lift the pump and follower plate | 5 | Inlet general air supply into filter and lubricator            |
| 2B | Down position to activate the press-fluid       |   |  |